

Interim report for the third quarter of 2006¹

Solid operations, more robust

Aker continues its positive development. The Aker Group's EBITDA at the close of the first nine months of 2006 amounted to NOK 3.4 billion, up more than 50 percent compared with the corresponding 2005 reporting period. The Group's NOK 152 billion order backlog as of 30 September establishes a solid foundation for future earnings.

The Aker Group had third-quarter 2006 revenues of NOK 20 billion; EBITDA for the quarter was NOK 1.1 billion. The EBITDA is on a par with the four preceding quarters. Aker Kværner continues its strong profit growth; at Aker Yards, profit growth was curtailed by weak performance on one project and low capacity utilization in France. Profits at other Aker Group subsidiaries were mainly in line with previous quarters.

Demand for the Group's products and services continues to be great. The Aker Group's order backlog rose from NOK 88 billion as of 30 September 2005 to NOK 152 billion at the close of September 2006. Both Aker Kværner and Aker Yards won several major projects in the third quarter of 2006. The Aker Group's order backlog increased by NOK 30 billion in the third quarter of 2006.

A significant proportion of the Group's activities directly or indirectly depends on developments in the world's energy markets, global trade, and travel industry. The underlying trends in these segments are positive. Aker is well positioned to benefit from these fundamentally positive conditions and envisions continued growth in all main Group companies. The large order backlog provides the Group with a solid foundation for future earnings, and robustness regarding short-term market fluctuations.

Revenues, EBITDA, and order backlog Consolidated and by main company (Amounts in NOK million)	Third quarter		1 Jan. - 30 Sept.		Year
	2005	2006	2005	2006	2005
Revenues	15 463	20 283	43 023	59 950	62 450
EBITDA	897	1 089	2 177	3 397	3 322
Aker Kværner	539	822	1 356	2 265	2 145
Aker Yards	282	304	681	1 042	1 029
Aker American Shipping	19	1	104	20	131
Aker Seafoods	25	35	148	140	181
Aker Material Handling	5	17	14	39	35
Order intake	15 655	44 841	63 409	93 737	91 223
Order backlog (<i>as of close of period</i>)	88 127	151 960	88 127	151 960	98 371

¹⁾ Figure compilations, texts, and comments presented in this report refer to pro forma accounts and include revenues and EBITDA for activities held for sale (Aker Kværner's Pulping & Power business area) unless otherwise specified.

The stock market has been characterized, in part, by major fluctuations over the past six months. The market value of the Group's exchange-listed investments amounted to approximately NOK 29 billion at the close of trade on 2 November 2006, up from NOK 19 billion as of 1 January 2006.

The Aker Group's net financial items and other income was a negative NOK 206 million in the third quarter of 2006. Pre-tax profit for the third quarter of 2006 was NOK 601 million; profit for the reporting period for continued business activities amounted to NOK 465 million. Earnings per share (EPS) amounted to NOK 3.14 in the third quarter of 2006, and EPS for the first nine months of 2006 totaled NOK 14.34.

Refinancing of Aker Kværner

Sustained growth over several years and good prospects for the future enabled the Aker Group subsidiary Aker Kværner to negotiate new, more favorable loan agreements. By December 2006, at which point the refinancing is expected to be implemented, Aker Kværner will have achieved a significantly simplified financial, legal, and operational structure, compared with the current situation.

Upon implementation of the new loan agreements, the gross debt of Aker Kværner and the consolidated Aker Group will be cut by about NOK 1 billion. Significantly increased financial flexibility is another result: Interest costs will be reduced by some NOK 180 million annually, and Aker Kværner's dividend restrictions will be eliminated. The refinancing triggers a one-off negative accounting effect of approximately NOK 660 million the fourth quarter 2006.

Active ownership and business development

Aker ASA's business idea is to build and develop premier companies in industrial sectors in which the Aker Group holds a strong position. The Aker Group is an active owner that closely follows up developments in the Group's main business activities.

Subsequent to the listing of Aker Floating Production in the second quarter of 2006, the Aker Group includes six main exchange-listed companies (in addition to Aker ASA): Aker American Shipping, Aker Drilling, Aker Kværner, Aker Floating Production, Aker Seafoods, and Aker Yards. The main companies Aker Material Handling and Aker Capital are wholly owned by Aker.

Aker is continuously developing new projects and companies. Among these are the previously announced Aker BioMarine (formerly Aker Seafoods Corp.) and Aker Exploration.

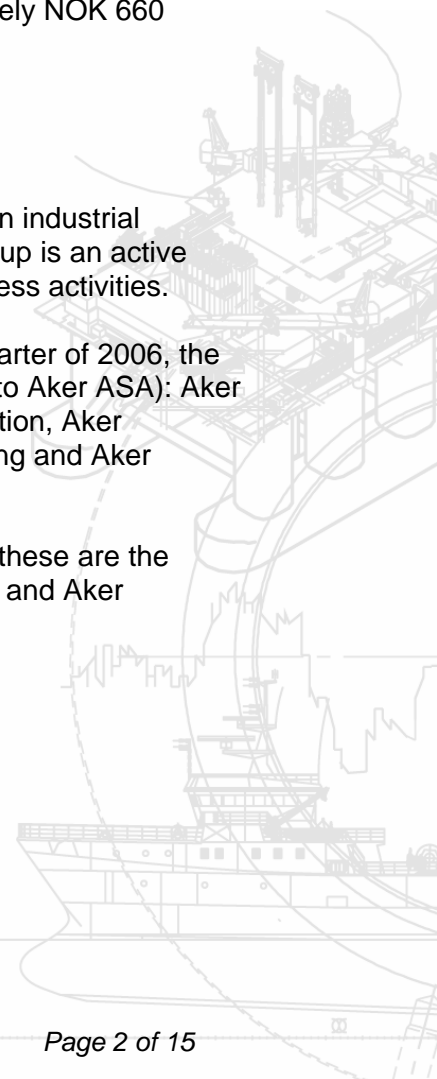

Aker BioMarine

Aker BioMarine's business idea is to harvest existing and hitherto unutilized marine biomasses and process these resources into high-value end products for the aquaculture, food, and pharmaceutical industries. Aker BioMarine's business activities include fisheries in Argentinean and Faeroe Island waters and harvesting and processing of krill in Antarctic waters.

In the third quarter of 2006, Aker BioMarine appointed Helge Midttun as new President and CEO. Mr. Midttun has broad experience in the aquaculture and food industries. He was President and Chief Executive Officer of the listed, integrated seafood company Fjord Seafood before joining Aker BioMarine, and is currently board chairman of the Norwegian food group Rieber & Co. Helge Midttun has also served as President and CEO of Det norske Veritas.

Aker Capital acquired a 41.9 percent shareholding in the listed biotechnology firm Natural ASA in the third quarter of 2006. Aker sees considerable potential in contributing to developing Natural, in parallel with Aker BioMarine's targeting of krill, and in close interaction with Aker BioMarine's other product development and marketing resources.

Preparations for building more advanced ships for harvesting and processing blue whiting and Antarctic krill have significantly progressed. Strengthening of the organization through recruitment of additional, key product development and sales personnel, and dialogue with relevant public authorities in order to ensure predictable framework conditions for activities, are also priorities.

As part of the continued development of Aker BioMarine, plans are to bring in new capital to the company through a private placement of shares. Listing on the Oslo Stock Exchange during the first half of 2007 is planned as a next step. Aker will continue to be Aker BioMarine's majority shareholder, but will reduce its ownership as part of the listing.

Aker BioMarine (EBITDA)	Third quarter		1 Jan. – 30 Sept.		Year
	2005	2006	2005	2006	2005
Argentina	37	9	51	58	42
Faeroe islands	(2)	(3)	6	28	5

Operationally, Aker BioMarine has developed as projected in the third quarter of 2006. Operating profits (EBITDA) in Argentinean and Faeroe Islands fisheries (see table) are characterized by normal seasonal variations. Commissioning of the sophisticated echo-harvester equipment for krill on board *Saga Sea* has continued since June, aiming for start-up of regular harvesting in the catch Season in the fourth quarter.

Aker Exploration

The development of Aker Exploration continues, as previously announced. The company will be a focused offshore exploration company, and a partner helping oil companies and public authorities identify additional oil and gas resources on the Norwegian continental shelf.

Aker Exploration's priority now is to establish agreements with operators and license holders to cooperate on specific offshore licenses. The company has secured loan commitments, and is preparing the applications necessary for approvals from public authorities. Aker Exploration is also evaluating offers from rig companies for chartering drilling platforms under long-term contracts.

Aker will consider inviting non-Group investors to join as Aker Exploration owners. The timing of such an investment process is assessed on an ongoing basis.

Aker ASA, holding companies and other activities

Aker ASA is the parent company of the Aker Group, and reports together with holding companies that are included in the parent company structure, other activities, and Group eliminations. Other activities comprises Molde Fotballklubb, Aker BioMarine (presented above), and Aker Capital.

Aker Capital owns 60 percent of the company Aker Invest, which in turn owns 25.9 percent of the listed company Odim ASA, all shares in the industrial company Midsund Bruk, and 35 percent of the base and logistics company NorSea Group, among others. Aker Capital also owns and controls shares of the listed companies Aker Drilling (35.3 percent), Bjørge (39.9 percent), and Natural (41.9 percent). These companies are not classified and reported as subsidiaries in the Aker Group's consolidated accounts.

Aker Capital previously held a minor ownership interest in the listed company Aker Floating Production ASA; the shareholding was sold to Aker ASA in the third quarter of 2006. Aker also acquired additional Aker Floating Production shares and now holds 50.1 percent of the company's stock; since then, Aker Floating Production has been consolidated in the Group accounts, along with other main Group companies.

The parent company of the Aker Group, Aker ASA, had third-quarter 2006 operating expenses totaling NOK 33 million (see table). Second-quarter 2006 sales gains are attributable to the establishment of Aker Floating Production.

Aker ASA Profit and loss account Amounts in NOK million	1Q 2006	2Q 2006	3Q 2006	YTD 2006
Sales gains	24	780	0	804
Operating expenses	(32)	(29)	(33)	(94)
EBITDA	(8)	751	(33)	710
Depreciation and amortization	(2)	(1)	(2)	(5)
Net financial items	41	(36)	84	89
Pre-tax profit	31	714	49	794

The parent company Aker ASA and holding companies that are included in the parent company structure had a solid balance sheet at the close of the third quarter (see table).

The most significant changes compared with the previous quarter are increases in cash and cash equivalents and interest-bearing debt to non-Group lenders. Both increases are associated with the issuance of a two-year, NOK 1 billion bond loan.

Interest-bearing fixed assets increased somewhat in the third quarter of 2006, largely as a result of foreign currency fluctuations.

Aker's investments figure in the balance sheet increased as a result of the Natural ASA share acquisition. Aker's total investment in Natural stock amounts to NOK 149 million, of which NOK 60 million is reflected in the third-quarter 2006 balance sheet.

Parent and holding companies Balance sheet Amounts in NOK million	31 Dec. 2005	30 June 2006	30 Sept. 2006
Intangible, fixed and non-interest-bearing assets	1 161	1 238	1 334
Interest-bearing fixed assets	1 934	1 511	1 669
Investments	8 612	9 506	9 569
Non-interest-bearing receivables and inventories	26	65	136
Interest-bearing short-term assets and cash	1 331	862	1 634
Assets	13 064	13 182	14 342
Equity	9 583	10 281	10 381
Non-interest bearing debt	1 308	272	332
Interest-bearing debt, Group	254	202	201
Interest-bearing debt, non-Group	1 919	2 427	3 428
Equity and liabilities	13 064	13 182	14 342
Net interest-bearing receivables / (liabilities)	1 092	(256)	(326)
<i>Equity ratio</i>	73%	78%	72%

Main Aker Group companies

Aker Kværner Amounts in NOK million	Third quarter		1 Jan. – 30 Sept.		Year
	2005	2006	2005	2006	2005
Operating revenues	10 073	13 400	28 189	38 986	41 463
EBITDA	539	822	1 356	2 265	2 145
Profit before tax	345	595	635	1 930	1 018
Order intake	11 795	24 625	38 096	53 683	57 748
Order backlog (as of close of period)	46 401	68 326	46 401	68 326	53 341

The overview includes the business area Pulping & Power, the sale of which has been agreed to. The sale is expected to be completed in the fourth quarter of 2006.

Aker Kværner continued its positive development in the third quarter of 2006. Operating profit (EBITDA) was NOK 822 million, compared with NOK 539 million in the third quarter of 2005. Aker Kværner achieved an EBITDA margin of 6.1 percent, up from 5.4 percent in the corresponding 2005 reporting period.

The Aker Kværner Group's third-quarter 2006 order intake was NOK 24.6 billion, the highest-ever quarterly intake of new orders. At the close of September 2006, the order backlog had reached a solid NOK 68.3 billion.

Due to continued high capacity utilization in the industry, Aker Kværner will continue to selectively focus on project bids that are best suited to its strengths and profitability — and on project completion excellence. The company's markets are expected to continue to be strong, offering attractive business opportunities.

Aker Kværner is a listed company; its shares trade on the Oslo Stock Exchange (ticker: AKVER). At the close of trade on 2 November 2006, the per-share price of Aker Kværner stock was NOK 677.00; accordingly, the market value of Aker's 50.01 percent shareholding in Aker Kværner was NOK 18.6 billion.

Aker Yards Amounts in NOK million	Third quarter		1 Jan. – 30 Sept.		Year 2005
	2005	2006	2005	2006	
Operating revenues	4 219	6 505	11 710	18 046	16 607
EBITDA	282	304	681	1 042	1 029
Profit before tax	215	176	511	769	704
Order intake	3 540	19 995	24 313	38 986	32 084
Order backlog (as of close of period)	35 457	77 519	35 457	77 519	38 897

Aker Yards' third-quarter profit fell short of the shipyard group's goal. Below-expectations profitability is primarily attributable to a design error that impacted profit on the serial production of three merchant ships, and weaker margins on certain projects due to subcontractors failing to meet delivery deadlines. A NOK 90 million charge for capacity costs related to underutilization at recently acquired Aker Yards France also cut into third-quarter 2006 profit.

Third-quarter 2006 EBITDA was NOK 304 million, up from NOK 282 million in the third quarter of 2005. Due to strong growth in operating revenues, the EBITDA margin for the third quarter of 2006 was 4.7 percent, compared with 6.7 percent in the corresponding 2005 reporting period.

Strategic acquisitions in the Merchant Vessels business area were completed in the third quarter of 2006: Damen Shipyards Okean in Ukraine (a joint venture) and the purchase of Kleven Florø AS and Kleven Design AS in Norway.

Order backlog growth continued in the third quarter. Order intake in the quarter amounted to NOK 20 billion. As of 30 September 2006, Aker Yards' order backlog comprised 150 vessels at a total value of NOK 77.5 billion.

Aker Yards is listed on the Oslo Stock Exchange (ticker: AKY). Aker Yards shares closed at NOK 467.00 on 2 November 2006; accordingly, Aker's 50.4 percent shareholding in Aker Yards ASA had a market value of NOK 5.3 billion.

Aker American Shipping Amounts in NOK million	Third quarter		1 Jan. – 30 Sept.		Year 2005
	2005	2006	2005	2006	
Operating revenues	187	20	1 474	236	1 615
EBITDA	19	1	104	20	131
Profit before tax	68	16	76	47	84
Order intake	-	-	-	-	0
Order backlog (as of close of period)	5 958	5 699	5 958	5 699	5 830

Aker American Shipping is developing as expected, and market interest in the company's product tankers is considerable. Until product tanker deliveries are made, operating revenues are limited to the delivery of the last in a series of four containerships. The customer, Matson Navigation, has expressed great satisfaction with the containerships Aker American Shipping delivered in the period 2003-2006.

The operating profit (EBITDA) for the third quarter of 2006 amounted to NOK 1 million, compared with a NOK 19 million in the corresponding 2005 reporting period. The Philadelphia shipyard's NOK 6 billion order backlog comprises a series of ten product tankers for delivery to shipowning subsidiaries of Aker American Shipping. The first four product tankers are under construction; delivery of the first tanker, currently 90 percent completed, is scheduled for late 2006.

Overseas Shipholding Group (OSG), Aker American Shipping's US partner, has entered into a contract with Aker American Shipping for bareboat charter agreements covering the first ten product tankers in the current newbuilding series. In the third quarter, two new charter agreements were concluded with end-users in the United States. Thus far, long-term charter agreements have been concluded for eight of the ten product tankers: four with Tesoro, two with BP, and two with Shell. The market for charter agreements for such vessels is developing favorably.

Aker American Shipping is a listed company; its shares trade on the Oslo Stock Exchange (ticker: AKASA). On 2 November 2006, Aker American Shipping stock closed at NOK 94.00; accordingly, Aker's 53.2 percent direct ownership interest in Aker American Shipping had a market value of NOK 1.4 billion.

Aker Seafoods Amounts in NOK million	Third quarter		1 Jan. – 30 Sept.		Year 2005
	2005	2006	2005	2006	
Operating revenues	455	400	1 802	1 582	2 339
EBITDA	25	35	148	140	181
Profit before tax	(6)	(2)	42	37	41

Aker Seafoods had a third-quarter 2006 operating profit (EBITDA) of NOK 35 million, compared with NOK 25 million in the third quarter of 2005. Higher market prices for white fish, along with improved operations contributed to Aker Seafoods' third-quarter 2006 profit margin growth.

Third-quarter 2006 operating revenues were NOK 400 million, compared with NOK 369 million in the corresponding 2005 reporting period, adjusted for the sale of the Nordic Group.

Aker Seafoods achieved a third-quarter 2006 EBITDA margin of 8.7 percent, up from 5.5 percent in the third quarter of 2005. EBITDA margin growth was a pronounced improvement, in a traditionally weak quarter for the white fish industry.

Aker Seafoods has strengthened its grip on the entire value chain — harvesting, processing, sales, and distribution. The Harvesting business area continued its growth in the third quarter. Aker Seafoods is increasingly targeting its own brand names, such as Thorfisk in Denmark and Aker Seafoods in Norway and Sweden, along with food retailers' private-label brands.

The third quarter 2006 profit and loss account includes a NOK 42 million profit item, the result of a tax benefit not previously recorded in the balance sheet. Aker Seafoods' after-tax profit as of 30 September, including the effect of the tax benefit, was NOK 76 million, compared with NOK 35 million as of the same date in 2005.

Aker Seafoods is a listed company; its shares trade on the Oslo Stock Exchange (ticker: AKS). On 2 November 2006, Aker Seafoods shares closed at NOK 30.00; accordingly, the market value of Aker's 65 percent ownership interest in Aker Seafoods was NOK 0.9 billion.

Aker Floating Production Amounts in NOK million	Third quarter		1 Jan. – 30 Sept.		Year 2005
	2005	2006	2005	2006	
Operating revenues	-	-	-	-	-
EBITDA	-	(11)	-	(24)	-
Profit before tax	-	(40)	-	(15)	-

Aker Floating Production has purchased three ships to be converted into offshore production vessels, so-called FPSOs (Floating Production, Storage, and Offloading). The market for such chartered oil production facilities is in rapid growth. Aker Floating Production is pursuing several attractive business prospects and specific projects.

Recently established Aker Floating Production had a third-quarter 2006 operating loss (EBITDA) of NOK 11 million; profit performance is in accordance with the company's business plan.

In August, an agreement was entered into with Koch Inc. to charter the vessel *Aker Smart 3* for crude oil storage purposes. The agreement runs for 180 days, beginning 20 October 2006. Apart from this charter agreement, Aker Floating Production is not expected to generate revenues until the fourth quarter of 2007.

Aker Floating production was listed in the second quarter of 2006; its shares trade on the Oslo Stock Exchange (ticker: AKFP). On 2 November 2006, Aker Floating Production shares closed at NOK 73.00; accordingly, the market value of Aker's 50.1 percent ownership interest in Aker Floating Production was NOK 0.8 billion.

Aker Material Handling Amounts in NOK million	Third quarter		1 Jan. – 30 Sept.		Year
	2005	2006	2005	2006	2005
Operating revenues	300	388	935	1 117	1 347
EBITDA	5	17	14	39	35
Profit before tax	(5)	0	(15)	0	(13)
Order intake	320	372	1 000	1 219	1 391
Order backlog (as of close of period)	311	416	311	416	303

Aker Material Handling's operating revenues and profits are continuing to grow. In the third quarter of 2006, the Aker Material Handling Group's revenues amounted to NOK 388 million, up 29 percent compared with the corresponding 2005 reporting period. EBITDA for the third quarter of 2006 was NOK 17 million, compared with NOK 5 million in the third quarter of 2005. Operational improvements and market growth resulted in margin growth.

Aker Material Handling had operating revenues for the first nine months of 2006 of NOK 1,117 million; EBITDA for the period was NOK 39 million. For the corresponding reporting period in 2005, operating revenues amounted to NOK 935 million, and EBITDA was NOK 14 million.

Aker Material Handling is advancing in all market regions. The Group's Scandinavian and German markets showed the strongest growth. The factory in the Netherlands is showing good results. Earlier this year, Aker Material Handling established offices in Algeria, and in the third quarter was awarded a major contact with the petroleum and energy company Sonatrach. In the United Kingdom, Aker Material Handling's sales and distribution organization has been strengthened through staff recruitment. In the UK market as well, key orders were won in the third quarter.

Aker Material Handling's third-quarter 2006 order intake was NOK 372 million. The order backlog was NOK 416 million at the close of the third quarter, up 34 percent compared with the year-earlier figure.

Aker Material Handling is a wholly owned Aker subsidiary.

Oslo, 2 November 2006
Board of Directors
Aker ASA

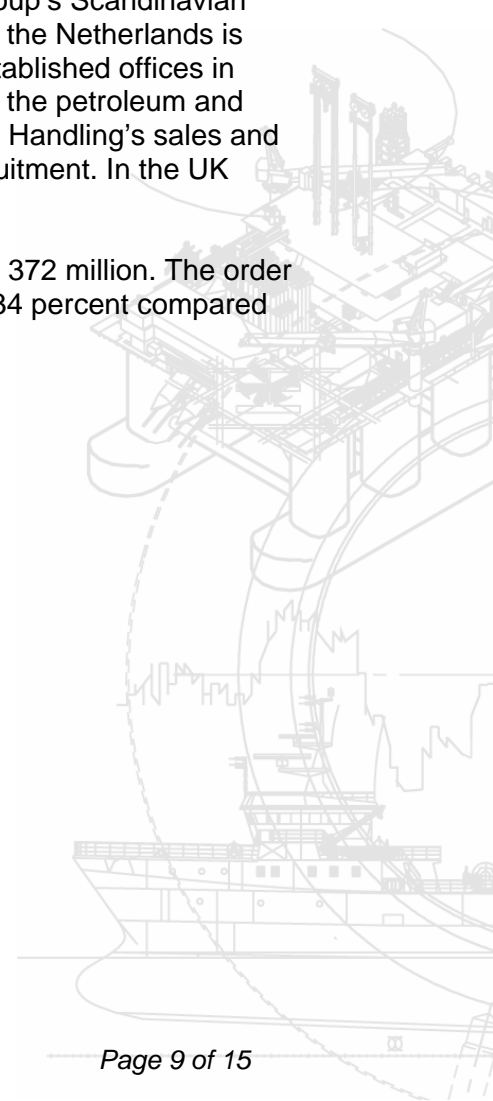

Aker Group

INCOME STATEMENT

Amounts in NOK million	Note	1Q 2006	2Q 2006	3Q 2006	3Q 2005	January-September 2006	January-September 2005	Year 2005
Operating revenues		17 159	20 151	18 942	14 414	56 252	39 850	57 927
Operating expenses		-16 068	-19 052	-17 914	-13 594	-53 034	-37 893	-54 934
Operating profit before depreciation and amortization		1 090	1 100	1 028	821	3 218	1 957	2 993
Depreciation and amortization		-206	-214	-220	-203	-641	-565	-798
Impairment changes and non recurring items		0	0	-1	-7	0	-13	-69
Operating profit		884	885	807	610	2 577	1 380	2 125
Net financial items		-183	-42	-206	-155	-431	-661	-832
Other income		0	403	0	0	403	0	1 041
Profit before tax		702	1 246	601	455	2 549	718	2 333
Income tax expense		-260	-217	-137	-94	-614	-538	64
Net profit/loss from continuing operations		441	1 029	465	361	1 935	180	2 397
Discontinued operations:								
Profit for the period from discontinued operations	6	34	34	44	47	112	145	193
Profit for the period		475	1 063	509	408	2 047	325	2 590
Minority interest		366	361	281	199	1 009	401	976
Equity holders of the parent		109	702	227	209	1 038	-76	1 614
Average number of shares outstanding (million)		72,4	72,4	72,4	77,0	72,4	77,0	76,6
Basic earnings per share continuing business (NOK)	6	1,03	9,23	2,53	2,10	12,79	(2,87)	18,56
Basic earnings and diluted earnings per share (NOK)		1,50	9,70	3,14	2,72	14,34	(0,98)	21,07

CASH FLOW STATEMENT

Amounts in NOK million	1Q 2006	2Q 2006	3Q 2006	3Q 2005	January-September 2006	January-September 2005	Year 2005
Cash flow from operating activities	(887)	468	2 214	820	1 795	(1 236)	3 632
Cash flow from investing activities	(565)	94	(154)	(540)	(625)	(373)	1 211
Cash flow from financing activities	143	(143)	1 131	974	1 131	1 181	(594)
Cash flow in the reporting period	(1 309)	419	3 191	1 254	2 301	(428)	4 249
Effects of changes in exchange rates on cash	(20)	(121)	323	(59)	182	8	44
Cash and cash equivalents at the beginning of period	12 379	11 050	11 348	6 471	12 379	8 086	8 086
Cash and cash equivalents at end of period	11 050	11 348	14 862	7 666	14 862	7 666	12 379

Aker Group

BALANCE SHEET

Amounts in NOK million	Note	At 31.03	At 30.06	At 30.09	At 30.09	Year
		2006	2006	2006	2005	2005
Assets						
Non-current assets						
Property, plant & equipment		6 548	7 414	8 330	6 251	6 523
Intangible assets		8 647	8 665	9 326	8 627	8 798
Deferred tax assets		2 200	1 946	1 984	1 777	2 221
Investment in associated companies		1 147	1 802	1 290	540	1 191
Other shares		399	275	373	371	235
Interest-bearing long-term receivables		695	707	755	560	1 020
Other non-current assets		351	345	385	272	331
Total non-current assets		19 986	21 155	22 442	18 398	20 319
Current assets						
Inventory, trade and other receivables		24 981	24 351	25 244	18 919	23 749
Interest-bearing short term receivables		1 022	844	892	489	832
Cash and bank deposits		11 050	11 348	14 862	7 666	12 379
Total current assets		37 053	36 542	40 998	27 074	36 960
Assets discontinued operations classified as held for sale	6	2 304	2 446	2 803	0	0
Total assets		59 343	60 143	66 243	45 472	57 279
Equity and liabilities						
Equity						
Paid in capital		8 521	8 521	8 521	7 807	8 521
Retained earnings and other reserve		-778	20	291	-1 661	-416
Total equity attributable to equity holders of the parent		7 743	8 541	8 812	6 146	8 105
Minority interest		7 159	7 684	8 782	6 141	6 841
Total equity		14 902	16 225	17 594	12 287	14 946
Non-current liabilities						
Interest-bearing loans	5	8 411	9 722	10 178	8 491	8 186
Subordinated debt		3 197	3 145	3 275	3 033	3 167
Deferred tax liability		744	664	718	737	643
Provisions and other long-term liabilities		1 922	2 052	2 139	2 213	2 122
Total non-current liabilities		14 274	15 583	16 309	14 474	14 118
Current liabilities						
Short-term debt interest-bearing debt	5	5 050	2 097	4 234	1 455	4 473
Tax payable, trade and other payables		22 705	23 691	25 301	17 256	23 742
Total current liabilities		27 755	25 788	29 535	18 711	28 215
Liabilities discontinued operations held for sale	6	2 412	2 548	2 805	0	0
Total liabilities		44 441	43 918	48 649	33 185	42 333
Total equity and liabilities		59 343	60 143	66 243	45 472	57 279

STATEMENT OF CHANGES IN EQUITY

Amounts in NOK million	1Q	2Q	3Q	3Q	January-September		Year
	2006	2006	2006	2005	2006	2005	2005
As of beginning of period	8 105	7 743	8 541	5 974	8 105	6 120	6 120
IAS 39	0	0	0	0	0	100	100
Net profit	109	702	227	209	1 038	-76	1 614
Valuation differences	52	0	31	22	83	22	23
Cash flow hedges	-14	232	-260	0	-42	0	0
Merger effects	0	0	0	0	0	0	1 330
Dividend	-470	0	0	0	-470	0	-1 013
Translation and other differences	-39	-136	273	-59	98	-20	-69
As of end of period	7 743	8 541	8 812	6 146	8 812	6 146	8 105

Notes to the consolidated interim financial statements 3rd Quarter 2006

1. Reporting entity

Aker ASA is a company domiciled in Norway. The consolidated interim financial statements for the first 9 months of 2006 ended 30 September comprise Aker ASA and its subsidiaries (together referred to as the "Group" and the Group's interests in associates and jointly controlled entities.

The consolidated financial statements of the Group for the 2006 Quarterly reports and for the year ended 31 December 2005 are available at www.akerasa.com.

2. Statement of compliance

These consolidated interim financial statements have been prepared in accordance with international Financial Reporting Standards (IFRS) IAS 34 Interim Financial Reporting. They do not include all of the information required for full annual financial statements, and should be read in conjunction with the consolidated financial statements of the Group as at and for the year ended 31 December 2005.

There has not been issued any new IFRSs or interpretations after the completion of the consolidated financial statements for the year 2005. However some changes have been made, among other to IFRIC 4, IAS 19 and IAS 21. These changes have no material effect on Akers Group accounts.

These consolidated interim financial statements were approved by the Board of Directors on 2 November 2006.

3. Significant accounting principles

The accounting policies applied by the Group in these condensed consolidated interim financial statements are the same as those applied by the Group in its consolidated financial statements as at and for the year ended 31 December 2005.

4. Estimates

The preparation of interim financial statements requires management to make judgments, estimates and assumptions that affect the application of accounting policies and the reported amounts of assets and liabilities, income and expense. Actual results may differ from these estimates.

The significant judgments made by management in preparing these condensed consolidated interim financial statements in applying the Group's accounting policies and the key sources of estimation uncertainty were the same as those that applied to the consolidated financial statements as at and for the year ended 31 December 2005.

5. Loans and borrowings

The following material changes in interest-bearing debt during the first 9 months of 2006:

Amounts in NOK million	Long-term	Short-term excl. construction loans	Construction loans	Total interest-bearing debt
Balance 01.01.2006	8 186	437	4 036	12 659
Converting Convertible debt in Aker Yards	(221)			(221)
Sale of own bonds in Aker ASA	446			446
Other changes	-	(82)	659	577
Balance 31.03.2006	8 411	355	4 695	13 461
Refinancing bank loan in Aker Yards	375			375
New Bond loans in Aker Yards	593			593
Acquiring of Aker Yards France - seller credit	650			650
Other changes in 2nd Quarter	(307)	(86)	(2 867)	(3 260)
Balance 30.06.2006	9 722	269	1 828	11 819
Drawdown syndicate loan in Aker Yards	331			331
New Bond loan in Aker ASA	1 000			1 000
1. year instalment	(1 080)	1 080		-
Other changes in 3rd Quarter	205	39	1 018	1 262
Balance 30.09.2006	10 178	1 388	2 846	14 412

6. Discontinued operations

In the accounts the Pulping and Power businesses are presented as discontinuing operations, and financial data for Pulping and Power are as follows.

Income Statement

Amounts in NOK million	1Q 2006	2Q 2006	3Q 2006	3Q 2005	January-September		Year 2005
					2006	2005	
Operating revenues	1 041	1 316	1 341	1 049	3 698	3 173	4 523
Operating expenses	-980	-1 259	-1 280	-973	-3 519	-2 953	-4 194
Operating profit before depreciation and amortization	61	57	61	76	179	220	329
Depreciation and amortization	-13	-12	-14	-15	-39	-37	-50
Operating profit	48	45	47	61	140	183	279
Net financial items	-3	-7	19	5	9	19	-1
Profit before tax	45	38	66	66	149	202	278
Income tax expense	-11	-4	-23	-19	-38	-57	-85
Profit for the period	34	34	43	47	111	145	193

Balance Sheet

Amounts in NOK million	At 31.03 2006	At 30.06 2006	At 30.09 2006
Non-current operating assets	579	576	638
Current operating assets	1 725	1 870	2 165
Total operating assets	2 304	2 446	2 803
Non-current operating liabilities	125	124	134
Current operating liabilities	2 287	2 424	2 671
Total operating liabilities	2 412	2 548	2 805

CASH FLOW STATEMENT

Amounts in NOK million	1Q 2006	2Q 2006	3Q 2006	3Q 2005	January-September		Year 2005
					2006	2005	
Cash flow from operating activities	157	3	-86	214	74	137	158
Cash flow from investing activities	-36	-18	-50	-19	-104	-62	-104
Cash flow from financing activities	60	153	189	-243	402	-65	67
Cash flow in the reporting period	181	138	53	-48	372	10	121
Effects of changes in exchange rates on cash	9	-32	41	3	18	2	13
Cash and cash equivalents at the beginning of period	508	698	804	431	508	374	374
Cash and cash equivalents at end of period	698	804	898	386	898	386	508

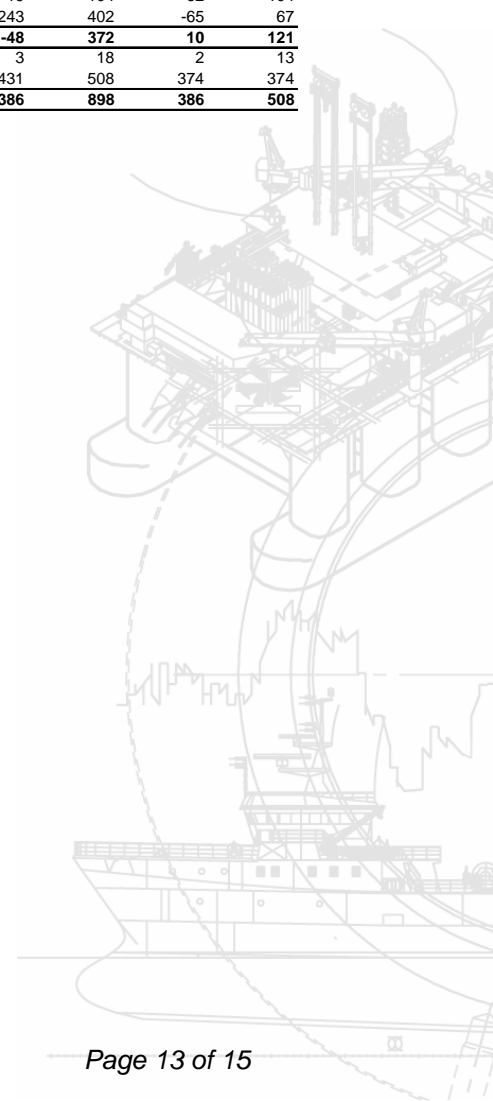

7. Business Combinations

Establishing joint ownership of Damen Shipyards Okean

Aker Yards and Damen Shipyards Group have on 4 August 2006 finalized the process of establishing joint ownership of the Damen Shipyards Okean, as announced 2 June 2006.

Aker Yards will manage the yard, and will in addition to the existing projects, primarily focus the Group's production of merchant vessels. The operations will be consolidated into Aker Yards accounts as of fourth quarter 2006. The impact for the third quarter would not have been significant. Aker Yards has paid EUR 10 million in cash. Additional payments will depend on the future performance of the yard. Aker Yards will also assume or procure repayment of EUR 11 million of debt. Additional information according to IFRS 3 is not in place and can not be given in this period.

Acquisition of Kleven Florø AS and Kleven Design AS

On 7 August 2006, Aker Yards finalized the transaction with Kleven Maritime to acquire Kleven Florø AS and Kleven Design AS. The companies have changed names to Aker Yards Florø AS and Aker Yards Florø Design AS. The two companies have been consolidated into Aker Yards' group accounts as of closing date.

Aker Yards has acquired Kleven Florø and Kleven Design at a price of approximately NOK 60 million including debt, and will compensate for working capital in excess of zero. In addition there will be further payments based on performance on existing order backlog and new orders in the coming three years.

Additional information according to IFRS 3 is not in place and can not be given in this period.

Business combination, achieved in stages - Aker Floating Production

Aker established the company Aker Floating Production in the first quarter of 2006 as a wholly-owned subsidiary. Aker Floating Production plans to build, own and operate a fleet of Smart FPSOs for production and storage of oil and gas. It is the current intention to own four such Aker Smart FPSOs.

In April Aker increased the equity in the company through a contribution in kind of USD 125.9 million. The company was at the same time capitalized through a private placement of USD 150 million. It was issued 12 million new shares at a share price of NOK 81.0 per share. Aker's original shareholding in the company was in the private placement valued to NOK 789 million.

Aker invested USD 10 million in the private placement and owned 48.4% of the company following the private placement. The company was listed on Oslo Børs on the 26th of June 2006. Aker ASA recognized a gain of NOK 780 million in the transactions whereas the gain for the Aker Group was NOK 403 million. The difference in recognized value of NOK 377 million between Aker ASA and Aker Group is deferred gain that reduces the excess value recognised in the accounts of Aker Floating Production.

On the 11th of August 2006 Aker ASA acquired 383.000 shares in Aker Floating Production ASA at a share price of NOK 76.00 per share. Aker ASA and the wholly-owned subsidiary Aker Capital combined shareholding after this transaction is 11.022.506 shares that constitute 50.01 percent of the total shareholding in Aker Floating Production ASA.

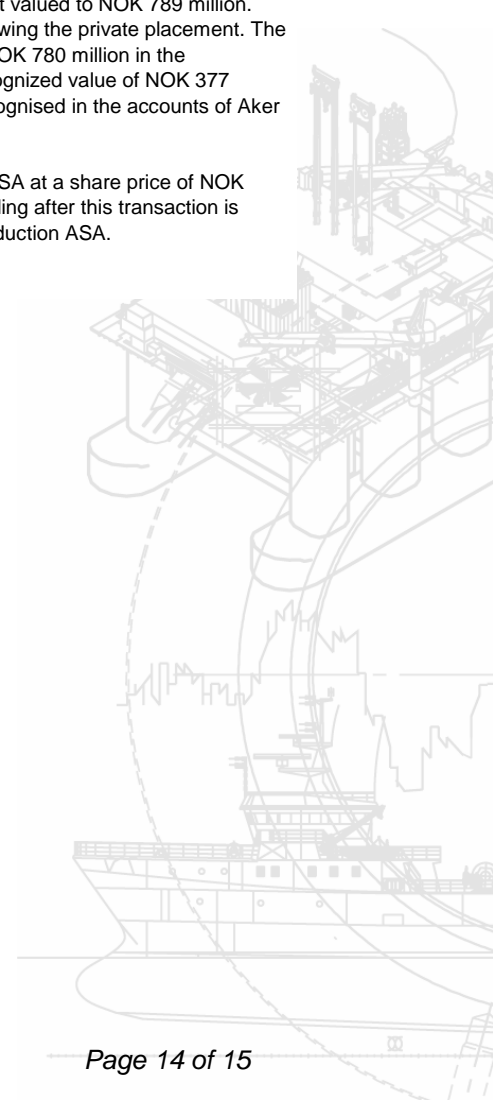

Business combination, achieved in stages - Aker Floating Production (cont)

Details of net assets acquired and goodwill are as follows:

Purchase consideration (NOK million):

Cash paid and contribution in kind	884
Deferred gain in the Aker Group	(377)
Total purchase consideration less deferred gain	507
Fair value of net assets acquired	884
Deferred gain in the Aker Group	(377)
Total fair value of net assets acquired less deferred gain	507
Goodwill	(0)

The assets and liabilities arising from the acquisition are as follows:

Amounts in NOK million	Recognised values	Fair value adjustments	Booked value in company acquired
Intangible assets	786	-	786
Property, plant and equipment	158	-	158
Other non-current assets	12	-	12
Inventory and interest free current assets	41	-	41
Cash and cash equivalents	713	-	713
Total Assets	1 709	-	1 709
Interest bearing liabilities	-	-	-
Non-current provisions	-	-	-
Accounts payable and other short term liabilities	(6)	-	(6)
Current provisions	-	-	-
Net assets	1 703	-	1 703
Minority interests	(819)	(819)	-
Net assets acquired	884	(819)	1 703

The figures above are not finalized and may be changed in subsequent periods.

8. Business segments
Business segments

Amounts in NOK million	Operating revenues							Operating profit before depreciation and amortization (EBITDA)						
	1Q 2006	2Q 2006	3Q 2006	3Q 2005	January-Sept 2006	January-Sept 2005	Year 2005	1Q 2006	2Q 2006	3Q 2006	3Q 2005	January-Sept 2006	January-Sept 2005	Year 2005
Aker Kværner incl. Pulping & Power	11 588	13 998	13 400	10 073	38 986	28 189	41 463	710	733	822	539	2 265	1 356	2 145
Aker Yards	5 397	6 144	6 505	4 219	18 046	11 710	16 607	357	382	304	282	1 042	681	1 029
Aker American Shipping 1)	125	91	20	187	236	187	345	18	1	1	19	20	19	35
Aker Seafoods	605	577	400	455	1 582	1 802	2 339	67	38	35	25	140	148	181
Aker Material Handling	340	389	388	300	1 117	935	1 347	9	13	17	5	39	14	35
Other, eliminations	145	268	-430	229	-17	200	349	-10	-10	-91	27	-109	-41	-103
Proforma	18 200	21 467	20 283	15 463	59 950	43 023	62 450	1 151	1 157	1 089	897	3 397	2 177	3 322
Pulping & Power (classified as held for sale)	-1 041	-1 316	-1 341	-1 049	-3 698	-3 173	-4 523	-61	-57	-61	-76	-179	-220	-329
Accounts	17 159	20 151	18 942	14 414	56 252	39 850	57 927	1 090	1 100	1 028	821	3 218	1 957	2 993

1) The revenue and EBITDA for Aker American Shipping are shown in this note includes the revenue and EBITDA from the time of Akers acquisition 30 June 2005.

Aker Kværner business segments

Amounts in NOK million	Operating revenues							Operating profit before depreciation and amortization (EBITDA)						
	1Q 2006	2Q 2006	3Q 2006	3Q 2005	January-Sept 2006	January-Sept 2005	Year 2005	1Q 2006	2Q 2006	3Q 2006	3Q 2005	January-Sept 2006	January-Sept 2005	Year 2005
Field Development	3 681	4 056	4 215	2 476	11 952	7 350	10 620	234	263	252	161	749	419	632
MMO	1 985	2 547	2 343	2 083	6 875	5 197	7 452	108	121	113	89	342	199	290
Subsea, Products & Technologies	2 671	3 357	3 390	2 446	9 418	6 857	9 854	173	225	287	177	685	430	654
Process	2 775	2 873	2 568	2 236	8 216	6 177	9 625	75	86	142	50	303	135	224
Other	-565	-151	-457	-217	-1 173	-565	-611	59	-19	-33	-14	7	-47	16
Total	10 547	12 682	12 059	9 024	35 288	25 016	36 940	649	676	761	463	2 086	1 136	1 816
Pulping & Power (classified as held for sale)	1 041	1 316	1 341	1 049	3 698	3 173	4 523	61	57	61	76	179	220	329
Total incl. Pulping and Power	11 588	13 998	13 400	10 073	38 986	28 189	41 463	710	733	822	539	2 265	1 356	2 145